

# **Dialectic, Algebra and Panpsychism**

(The Time Vortex Principle)

Alanas Petrauskas

Heraclitus, Inc., 2251 Pathfinder Drive, Burlington, ON L7L 6L6, Canada

M. Marcinkevičiaus 17 – 15, Vilnius, 08433 Lithuania

[alanas196560@gmail.com](mailto:alanas196560@gmail.com)

tel. +37061594374

**THE FIRST PRE-DRAFT**

## **Abstract**

All phenomena are suggested to have inherent directedness and self-regulating capability that can be described by the 4-dimensional quaternions and higher algebras. This explains the essence of dialectics, time and Life (in their broadest senses). Self-regulating systems create new “existential dimensions” that make them thermodynamically “open”, thus solving the problem of increasing entropy and enabling uninterrupted evolution. Any disruptions occur only because we follow the “relativistic” thinking, disregarding the natural sequence of events. A “comforting” model of the Living Universe is given, that may help to reduce this struggle and develop the “universal problem solving” system.

**Keywords:** Dialectic, Unity of Opposites, Algebra, Pansychism

The emerging global challenges and artificial intelligence pose serious question regarding the validity of our common sense and philosophy in general. The very fact that humanity faces a wide range of global problems (environmental, poverty, health, *etc.*) indicates that our “common sense” is flawed. Ultimately it starts with the “relativistic” thinking, assuming that everything can be measured by the “simple scalar numbers”, such as size, weight, energy or price. This creates a deceptive impression that everything can be measured and confuses of what is right and wrong.

In the meantime, all phenomena have the inherent directedness yielding self-regulation, *a.k.a.* the “heart and mind”. It cannot be measured, but can be sensed as a struggle, problem, or opposition. To solve this problem, we must tackle an independent, but related problem. In other words, two oppositions cannot unite without an external help of another pair of oppositions. Both pairs must maintain the “mutual neutrality”, yet be able to transform to each other. Such transformations, in a specific sequence, create the “centripetal force”, lifting counterparts to their subtler forms. It is akin to a self-regulating vortex, arising from non-commutative vector operations. This vortex is suggested to be the actual source of Life, Morality and Matter, yielding a simple yet “mind-blowing” model of the Universe. These principles can be used for solving any practical and philosophical dilemmas.

### **Relativity vs. Dialectic**

Dialectic can be viewed as relativity raised to the power of two or more. What looks simple at the first sight, inevitably turns to be complex at the second sight. What looks like a “dead equilibrium”, always turns to be a steady-state kinetic process, and

what looks like a scalar value, always turns to be a multidimensional vector. At the first sight we seek to simplify phenomena, but at the second sight we strive to create something new. So it is like trifling and striving, and I wonder if the first step is actually necessary.

If an object freely moves from point 1 to point 2, then this movement is purely relativistic. But if it is related to struggle or resistance, then it becomes dialectic. The higher the struggle and sophistication, the more dialectic it becomes.

The resistance creates new perceptual dimension(s) as shown in Figure 1.

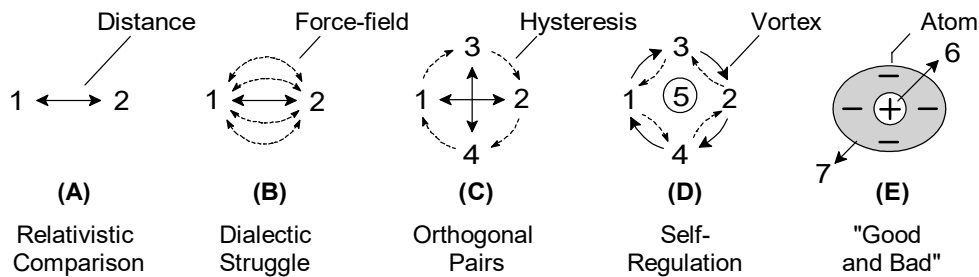

**Figure 1.** Evolution of dialectic system

Scheme A shows a relativistic comparison, B – repulsive interaction as a “dialectic struggle”. The latter immediately yields scheme C, where the original oppositions transform through intermediate steps. Although the original oppositions cannot transform to each other directly, there is always a way around the direct struggle.

Such transformations create hysteresis loop that may further become a self-regulating vortex or even an atom, as shown in schemes (D) and (E). It was a legitimate flow of thought in the 19<sup>th</sup> century, when Hamilton found that non-commutative 3-dimensional phenomena must be described by the 4-dimensional vectors (quaternions).

At the same time Helmholtz and Kelvin formulated their vortex theorems (reference), whereas Kelvin and Tait suggested that atoms represent 4-dimensional knots of aetheric fluid (Kochran, [Untying knots in 4 dimensions](#)).

Later these ideas were largely forgotten because of the Michelson - Morley experiments that discredited the idea of aether ([ref in wikipedia](#)), and Gibbs and Heaviside algebraic simplifications of vector rotations ([Crowe, 1969](#)). But today, when summarizing all phenomena from the formal machine learning perspective, the dialectic views of the 19<sup>th</sup> century may become actual again.

In the first place it concerns the “directedness” of all phenomena. If we screw a bolt to the right and then to the left, we will get a different result than if we first screwed to the left, and then to the right. Similarly, if we melt an amorphous solid and then freeze it, we will get a different result than if we first froze it and then melted. Such a directness is generally ignored in classic physics and thermodynamics, although it is easily explained by non-commutative operations of 4- and 8-dimensional vectors, quaternions and octonions, that are sometimes used in physics (Girard, 1984, 1999, Capozziello, et al, 2005), and “theories of everything” (Lisi and Weatherall, 2010, Furey, 2016, Weinstein, 2020, Wolfram, 2020, Caballero, 2020).

Another mysterious effect is the self-organizing capability of circular transformations. Why is the vortex flow so pervasive, circular thinking so appealing (Cole 2017), and repetitive psychological experiences so persistent (ref on self-regulating in psychology)? Why don't we relate them to biological homeostasis and general cyclicity of all processes in nature?

Gibbs and Heaviside described the cyclic rotation through the cross product of two vectors that yield the 3<sup>rd</sup> orthogonal vector (the "right hand rule"). But how can two abstract concepts create the 3<sup>rd</sup> concept, totally independent of the original two, without breaking the energy conservation law? Isn't this a proof that every rotation or cyclic transformation creates its own consciousness and existential meaning?

Scheme D explains the effect of vortex through the "closed push-pull" mechanism. Any resistance arises from incomplete alignment of the inherent (multidimensional) directedness. But if the alignment is complete, then this mechanism creates the "5<sup>th</sup> element" – an autonomous self-organizing system, where all constituents participate in every "local" transformation.

Algebraically it looks like vector transformations, where each vector represents an independent constituent, and each transformation involves all vectors at once. But physically it may look like a dynamic network of multifaceted interrelations among original constituents. An example may be a plasma crystal consisting of all 4 classic states of matter (Thomas, 2005); or a higher consciousness consisting of lower consciousness (will be considered below).

All of these are dramatic qualitative changes that we assign to remarkable achievements and inventions. Their value can be measured by the number of oppositions or mathematical dimensions that are united into a self-organizing system. If it involves only one pair of oppositions, then we obtain just an interesting idea or paradox. But if the number of (diverse) oppositions is larger, then we may obtain a “miracle” solution or creation.

This leads us to the scheme (E) that subdivides everything to the “right and wrong”, or more commonly, “good and bad”. Dialectically it stems from the above mentioned directness of all phenomena: clockwise or counterclockwise. But relativistic thinking ignores this relation, automatically marginalizing the outcome, and simply stating that the 5<sup>th</sup> element is “good”, whereas the original struggle is “bad”.

So we start fighting the non-existing problems. The 5<sup>th</sup> element cannot be antagonistic to the original oppositions, as it consists of them. Equally, the Truth cannot be antagonistic to the Lie, Safety to Danger, Equality to Corruption, *etc.* These are outcomes of different rotations that we neglectfully confuse while relying on relativistic principles. The most terrifying antagonism is not between the good and bad, but between the striving for directness and indifference of scalar values.

Scheme (E) also coincides with the structure of an atom, in which central proton is surrounded by an electron. Two types of electric charges arise from two directions of rotation, levels of subtleness and self-organization. Since electrons are the less organized form of matter than protons, so they carry more of the wave-like properties.

Haramain (2011) proposed that proton represents a miniature black whole, which agrees with the view that the 5<sup>th</sup> element creates a whole new dimension of existence. In scheme (E) it is represented as a new struggle 6 – 7 that creates a new force field orthogonal to the original hysteresis loop. This resembles a magnetic field orthogonal to electric current.

This new dimension has a finite size, defined by the area of hysteresis loop. Yet from inside it can represent an almost infinite world, due to the infinitesimal capillary networks among the original opposites. So a human body of less than 2 meters in length can involve 100,000 miles of blood vessels from inside. This may also mean the dual meaning of time, entropy, and all other scalar parameters

### **Comparison to Quaternions**

As already mentioned, the inner directedness of transformations is comparable to algebraic non-commutativity:  $A \times B \neq B \times A$ , where “x” implies the rotation of one vector around another. Assume (naively) that each vector represents a specific element / opposition, whereas rotation of one vector around another represents transformation (“dissolution”) of one opposite to another. In the case of 4 orthogonal vectors this means rotating one pair of vectors around another pair, as shown in Figure 2 (A-F).



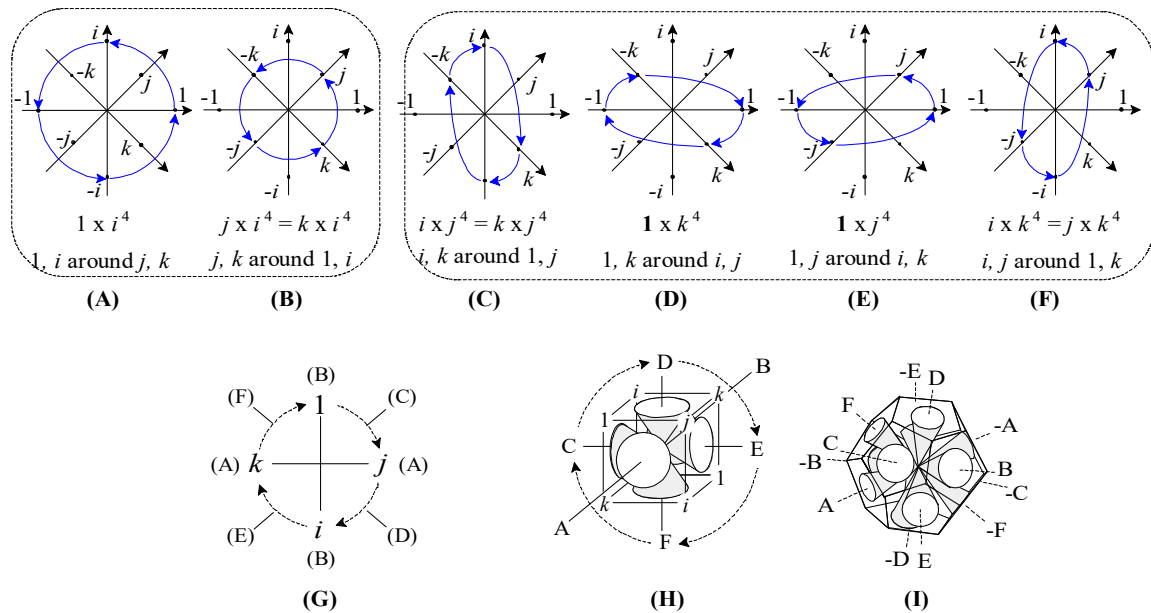

**Figure 2.**Quaternionic explanation of the self-regulation mechanism

How the rotation of one vector around another becomes the rotation of two vectors around another two? The rotation occurs in 2-dimensional plane, thus defined by two vectors that are orthogonal to another two vectors. So all vectors are not independent of each other, but act in pairs! This simple fact explains the very essence of dialectic, as well as the dialectic essence of algebra. All coordinates are not independent of each other, but related through “dialectic relativity”!

Scheme (G) represents the hysteresis loop from Figure 1. One can see that diagonal oppositions  $(1 + i$  and  $j + k)$  form vortices (A and B, respectively) that correspond to the permanent force-fields. Theoretically it can be related to the divergence operators in Maxwell’s equations, or the Gauss law of the electric charge or magnetic dipole distributions in respective fields. On the other hand, rotations A and B are totally symmetric, whereas electric and magnetic field equations are not symmetric (as magnetic charges are thought to be non-existent).

Transformation of one element to another is given by rotation of the remaining two vectors around the given pair. This reminds rotor operator in Maxwell's equations, or Faraday's and Ampere's laws of induction. On the other hand, four different rotations correspond to only two equations.

Most importantly, at any stage all elements are active, but their roles are changing, from the "leading axis" to the "serving rotors". This is the core essence of the self-regulation, that also coincides with the principle of hologram: every part reflects the whole. Enforcing or disrupting any stage affects all other stages respectively. If at any stage at least one element is lacking, the whole system becomes "sick" and self-regulation weakens.

This is quite different from what we naively assumed at the beginning, yet explains the "wholeness" principle of self-regulation. Scheme (H) suggests that the same principle can also explain the space-time continuum. Here the cube represents the space composed of two sets of quaternions. Each node represents a certain opposition, each face – a certain rotation (A-F). The central axis AB represents "entangled" pairs of oppositions that interact "dialectically" – in no time – explaining the origin of the [Bell's theorem](#). The remaining 4 rotations appear in a circular order that creates the sense of time.

Obviously space not just rotates, but transforms in many peculiar ways. But keep in mind that we consider the simplest possible algebraic system that supports non-commutativity. Furey (2016) described the same using a much more complex model of bioctonions – pairs of complex quaternions where each vector is multiplied by complex number. Below we will see that even Furey's model is an oversimplification.

The cube's surface area is likely to be related to the work in hysteresis loop. The smaller the cube, the smaller the work has to be done, and the faster the time flows. This is why the time runs fast when we unite, but creeps slowly, when we struggle.

A fast enough rotation should make all the nodes to unite into the pair of two 5<sup>th</sup> elements, in which case the entire cube should shrink to a single point. The latter may serve as the 5<sup>th</sup> node in pentagonal faces of dodecahedron in scheme (I). This is another hypothetical construct, in which time flows in both directions, yielding a pulsation, and reminding of the time reversal or [T-symmetry](#) (Bednorz et al, 2013) and [Loschmidt's paradox](#) (Wu, 1975).

These examples show that dialectic considerations are closely related to the algebra and the physics of time. In fact, time is just a sequence of events (senses, feelings, thoughts) that form hysteresis loops. Without the loops there would be no cyclicity of events, no resistance (inertia), and hence no time.

### **Thermodynamic Cycles**

Figure 3 (A) shows a typical thermodynamic cycle – the heat engine that produces mechanical work. If direction is reversed, we obtain the heat pump that produces heat from mechanical work.

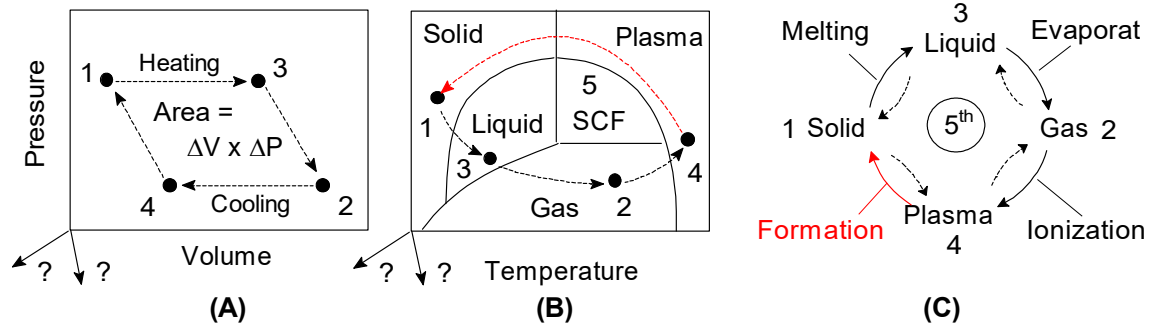

**Figure 3.** Thermodynamic cycles

It can be viewed as a relativistic system, since the loop is 2-dimensional and the 5<sup>th</sup> element is plain heat or work. To become dialectic, it must involve more diversified (multidimensional) transformations, that cannot be easily reversed. For example, schemes B and C show phase transitions (1 – 4) that can be regarded as 4-dimensional rotation, in which each phase represents a new dimension (given the existence of inter-dimensional states). The 5<sup>th</sup> element may represent plasma crystal, Bose-Einstein condensate, supercritical fluid (SCF), liquid crystal, superconductivity, or another exotic state or property of the matter.

The total work of n-dimensional hysteresis loop is given by the sum of all 2-dimensional surface areas,  $S_n = \sum S_{ij}$ , whereas the “richness” of the 5<sup>th</sup> element is given by the n-dimensional volume  $V_n$ . Under the constant sum of all dimensions, the maximum ratio  $V_n/S_n$  is achieved when all dimensions are equal to each other (schemes B, C), whereas the minimum when all but two dimensions approach zero (scheme A). In other words, the larger the diversity and dimensionality of the entire system, the higher the cooperation and the smaller the perturbations in each dimension can be achieved.

The real-life hysteresis loop involve more dimensions, given deviations from the ideal behavior – aggregation, filamentation, foaming, ionization, chemical and nuclear transformations. In the broadest case, the given cycle can represent all matter that enters the Earth (or Solar system) and leaves it into the outer space. So the 5<sup>th</sup> element can represent all Life on our Planet and beyond. It involves many smaller loops, such as biogeochemical (climate control), biochemical (like Krebs cycle), chemical (like Belousov – Zhabotinsky reaction), and nuclear (like [CNO cycle](#)). Each cycle yields either “pure energy” that triggers some the other cycles, or self-regulating mechanism that leads to higher consciousness.

Each cycle has preferred direction. For example, solid often melts, but rarely decays into plasma. Liquid mostly evaporates, but rarely freezes into solid, *etc.* On the other hand, self-regulation encompasses two opposite directions simultaneously. For example, the biotic pump model ([Makarieva and Gorshkov, 2010](#)) suggests that water condensates from air primarily because it evaporates from the leaves of trees. The sufficiently large evaporation causes larger than equivalent condensation, resembling the “pendulum-type” overcompensation, which in turn reduces local pressure, sucks more vapor from the ocean, and produces rain.

Since all of this happens on multiple dimensions, generation of the 5<sup>th</sup> element often goes unnoticed. So we assume that “everything is separated” and/or affected only by immediate surrounding

## Emotions' Cycles

Our moods and emotions also follow the same dialectic cycles, but their directions are not always obvious. Figure 4 compares few cycles. For the sake of comparison, all are aligned with the 4 classic elements: Fire (F), Earth (E), Water (W), Air (A).

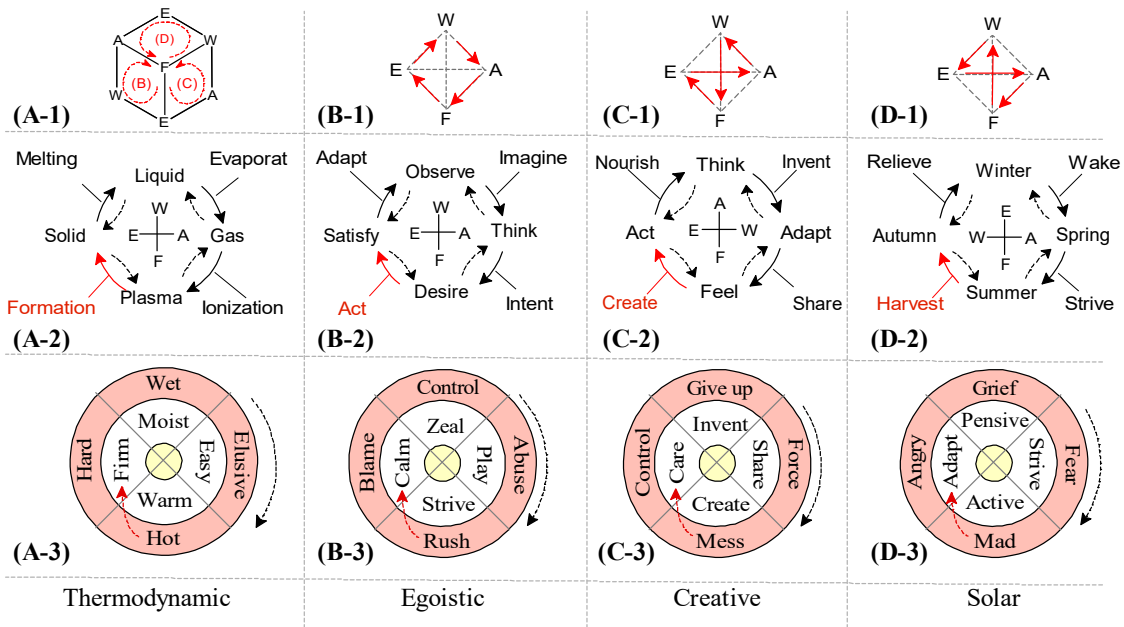

**Figure 4.** Comparison of emotion cycles

Each column represents certain type of emotions' transformations. Schemes in the first row (A-1 to D-1) show 3 circular sequences that yield self-regulation, whereas their reversion (in most cases) causes de-regulation. Red arrows in the second row indicate the least reversible steps.

Schemes of the third row show that clockwise transformations soften all perceptions (white cells) until they unite into the 5<sup>th</sup> element (yellow center). The latter

can have many names and levels, as we will see below: Pure Intent, New Life, Pure Love, Universal Intellect. It starts with the highest levels of the Maslow's pyramid and extends to the most sacred ideals of the wholeness. Below we will see that they are easier to describe algebraically than verbally.

The directedness of each cycle can be seen from the following considerations. In B-3, Calm can easily transform in a clockwise direction to Zeal, but it can hardly go backwards to Striving – instead it would get to Rashness. Zeal can smoothly transform to Playfulness, but hardly backwards to Calm – instead it will go to Blame and criticism. And so on.

In C-3, Invention can easily transform to Sharing, but hardly to Caring or Nurturing – instead it will turn to Control. In D-3, Pensiveness can easily transform to Striving, but hardly to Adaptation, instead it will get to Anger.

On the other hand, once the 5<sup>th</sup> element has been formed, it can rotate backwards without falling into rudeness. E.g., Calmness can become Striving, if accompanied by the Zeal and Playfulness. Action can transform to Awe, if accompanied by Romantic Gratefulness.

In real life several cycles may act simultaneously, thus confusing causes and effects. Each cycle can include many layers and transition stages, as shown in Figure 5, leading to extremely complicated situations. No wonder many people get lost in their feelings and priorities!

On the other hand, our schemes may help to unwind the complex feelings, understand the right and wrong directions, and identify the character traits and emotional development. They can be generated “on demand”, for solving particular dilemmas (see

Generation of Moral Laws), and the degree of detalization can potentially be very high (see [here](#) and [here](#)).

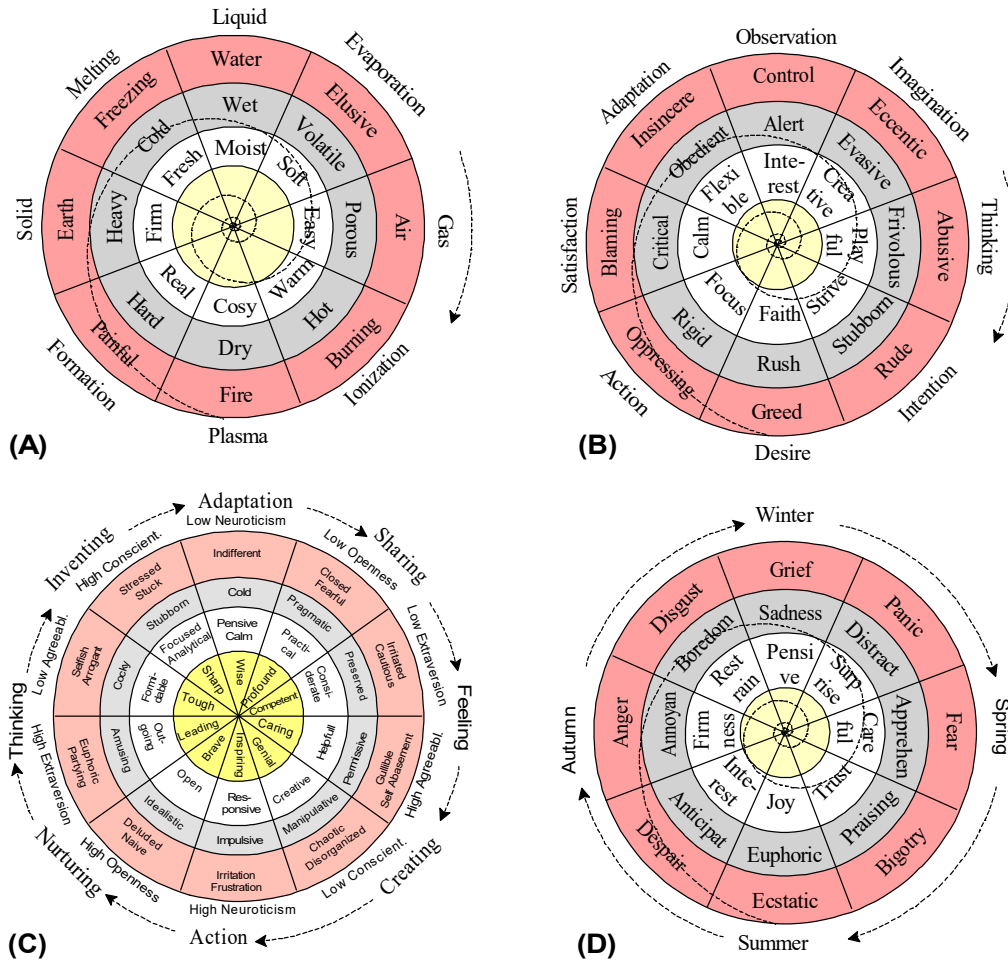

Figure 5. Dialectic wheels of feelings, emotions and character traits









### Algebra and Panpsychism

Since dialectic transformations can be modeled by algebraic vectors, we can use algebra for modeling the intellect. Table 1 identifies 3 groups of algebraic systems (A – C) representing three types of intellects: relativistic, dialectic, and creating / nurturing. Here  $N$  is the number of mathematical dimensions that composes a given intellect. It



coincides with the number of dialectic oppositions (emotions or perceptions) that creates a self-regulating system.

**Table 1.** Algebra and Dialectics

|          | Algebra |                            |                |   |                | Dialectics                               |   |
|----------|---------|----------------------------|----------------|---|----------------|--|---|
|          | $N$     | Numbers                    | Cell           | $K_N^*$   |                | Intellect type                           | Symbol  |
| <b>A</b> | 1       | Real                       | $A_1$          |  | 2              | Linear, formal logic                     | $1 + 1 = 2$<br>$y = f(x)$   |
|          | 2       | Complex                    | $A_2$          |  | 6              | Relativistic manipulation                |    |
|          | 3       | ---                        | $H_3$          |  | 12             | Spatial thinking, Physical reality       |    |
| <b>B</b> | 4       | Quaternion                 | $D_4$          | 24-cell   | 24             | “Pure intent”<br>– 4 opposites           |    |
|          | 8       | Octonion                   | $E_8$          |   | 240            | “New Life”?<br>– 8 opposites             |   |
| <b>C</b> | 24      | <i>Tri-octonions?</i>      | $\Lambda_{24}$ |   | 196,560        | <i>Pure Love?</i><br><i>24 opposites</i> |  |
|          | 240?    | <i>Octonion-Octonions?</i> | “ $X_{240}$ ”  |   | $\sim (24!)^2$ | <i>Universal Intellect?</i>              |   |

\*Kissing number – the greatest number of non-overlapping unit spheres that touch a common unit sphere.

**Group A includes commutative algebras** that do not yield self-regulation, thus can be assigned to “quasi-intellec[t]s”. These are relativistic intellects that are useful when all decisions have been made (by the higher intellects) and one just needs to implement the plan. But they are harmful when deciding on what is right and wrong.

$N = 1$  means that any single opposition represents a single-dimensional line of the real numbers. It yields the “linear thinking” assuming that opposites either “fight until one winner” (absolutism) or do not interact at all (relativism):  $1 + 1 = 1$  or  $2$ , respectively

$N = 2$  indicates two oppositions representing complex number plane. The operating idea is that  $1 + 1 = 2$  or  $3$ , as sum (or product) of two vectors yields the 3<sup>rd</sup> vector. Since complex number multiplication is commutative, such systems are not “self-organizing”, and so the 5<sup>th</sup> element is “dead” (recall the heat pump in Figure 3). It corresponds to various “dialectic” manipulations, such as Socrate’s Debates and Aristotle’s Rhetorics. In fact it is a purely relativistic manipulation based on the “pricing” and “weighting” arguments.

$N = 3$  corresponds to “spatial thinking” widely employed by modern physics, through partial differential equations. Yet it does not allow for unequivocal interaction of oppositions, as the product of 3-D vectors does not yield another 3-D vector. This was shown by Sir William Rowan Hamilton (nearly two centuries ago!), who introduced the 4<sup>th</sup> coordinate. Modern physics assigns this coordinate to the time in “space-time continuum”, although it is only needed for unambiguous 3D rotation. Thus all 4 coordinates are spatial, and modern physics is in trap.

**Group B includes non-commutative algebras** that yield self-regulating systems. Only two such cases are considered, as according to the [Adolf Hurwitz theorem](#) ([composition algebras](#)), multiplication of two vectors (sums of squares) yields another vector only under  $N = 1, 2, 4$  and  $8$ . Accordingly, only then rotation of one vector around another gives unambiguous result. All such cases have dashed background in Table 1.

These cases can be traced in many natural processes, and their wisdom is reflected in the symbolism of many spiritual traditions (Groff et al, 1996). They can be assigned to the first two (most stable) levels of the 5<sup>th</sup> element (in fact the 5<sup>th</sup> and the 9<sup>th</sup>) that can be associated with the higher consciousness available to humans.

$N = 4$  represents quaternions that describe various unique properties of particles ([google quaternions and particle physics](#)), 3-D chirality, and self-organization (as described above), [plus google quaternions and homeostasis](#))

Beyond non-commutativity, quaternions also yield the 6<sup>th</sup> Platonic solid – 24-cell, vertices of which are precisely the 24 Hurwitz quaternions ([Wikipedia, 24-cell](#)). It is also unique in that it has no analogues in other dimensions, yet is operative in generating two most exquisite cells in higher dimensions ( $E_8$  and  $\Lambda_{24}$ ).

From dialectical perspective  $N = 4$  associates with the natural “flawlessness and benevolence” – ability to sense the independent struggle – thus association with “Pure Intent”. It enables the opposites to “dissolve each other”, thus association with Yin and Yan.

$N = 8$  represents octonions that are used in “theories of everything” (Lisi and Weatherall, 2010), although often they are a part of a more complex systems (Furey, 2016, Weinstein, 2020, Wolfram, 2020, Caballero, 2020). Octonions yield  $E_8$  cell through Cayley integers (Baez, 2013). This cell is so beautiful (see [animation](#)) that it calls for a truly romantic interpretation.

If two parents with  $N = 4$  perceive each other’s oppositions as their own, they can form the  $E_8$  lattice (as a product of two sets of quaternions). This gives birth to a whole

new Universe, since  $K_8 = 240$  corresponds (or is close) to the number of dimensions that compose the Universe! We will give plenty of evidence to this statement below

Every part of the Hologram must possess all of its building blocks. So  $E_8$  must precede every “full-featured” birth, including even cell division – so we can associate it with a New Life and/or Mitosis.

(While most “common” creatures reach  $E_8$  only from time to time, other creatures may live in it permanently. Consider for example Gaia, our planet Earth, that transforms the seeds to plants and forests, while reversing “all physical laws” through biotic pump system (Makarieva and Gorshkov, 2010). Another possible example – Cosmic Microwave Background Radiation, that emits energy from “scattered space”, as if constantly giving birth to entire Universe. Any messages from  $E_8$  level cannot be expressed in a “relativistic” language, so we perceive them as either unspeakable bliss or outbreaks of disasters)

**Group C includes “Creating Algebras”** that “nourish” all other systems. Furey, 2016, Weinstein, 2020, Worlfram, 2020, suggested that algebra acts on itself to create our Universe. Building on this, we simply add that this “action” must be much more elegant than we can possibly imagine. So we make use of various “coincidences” that others hesitate to use, to arrive at a breath-taking proposition

$N = 24$  yields the Leech lattice,  $\Lambda_{24}$  (see [animation](#)), which is similar to  $E_8$  in that they both share the “universal optimality” (Cohn et al, 2019). It is also similar to all other cells from the dashed areas (related to Hurwitz algebras) as they all leave no free space

for the unit spheres to move. Yet it is much more grandiose, creating mind-blowing “supra-thermodynamic” and “nesting of dimensions” possibilities.

$24 = 8 \times 3$  could suggest a triple octonionic structure. John Baez pointed that  $24 = 6 \times 4$  means interaction between the only two regular plane tiling symmetries (so what?)

The “coincidental”  $K_4 = 24$  could suggest a reciprocal relation between the vertices of 4-dimensional 24-cell and 24 dimensions of  $\Lambda_{24}$ . Combining it with another (very likely) coincidence between  $K_8 = 240$  and  $X_{240}$  (the hypothetical cell of the Universe), we obtain the “extra-dimensional” self-regulating system in Figure 6, describing the “Family of Gods”.

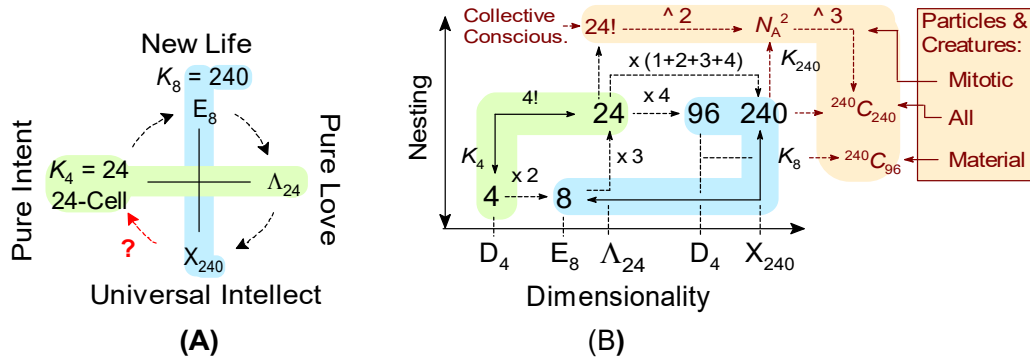

**Figure 6.** Possible interrelations of the higher cells

Case (A) shows the hysteresis loop in which the Universal Intellect ( $X_{240}$ ) nurtures the New Life ( $E_8$ , Mitosis), whereas the Pure Love ( $\Lambda_{240}$ ) nurtures the Pure Intent (24-cell). In return, two babies ( $D_4$  and  $E_8$ ) grant their parents ( $\Lambda_{240}$  and  $X_{240}$ ) an unimaginable bliss.

Circular rotation ( $4 \rightarrow 8 \rightarrow 24 \rightarrow 240 \rightarrow \dots$ ) merges the lower cells with the higher, thus creating new algebraic cells of intermediate dimensions. This may be the

whole point of the “God’s game”: create higher subtlety of existence through merging the lower intellects with the highest.

This game rejects the concept of the “closed thermodynamic systems”, since the lower cells are linked to the higher, as well as all religious movements, since the path to Universal Intellect (God) goes through creating New Life ( $E_8$ ) and Pure Love ( $\Lambda_{24}$ ). The opposite direction is counter-productive.

The ticket to this game is self-regulation ( $N = 4$ ), which cannot be gained through relativistic thinking nor technological advancements. Yet we can use these advancements as assisting tools.

Weinstein (2020) proposed that the Universe could have  $N = 248$  based on octonion-octonionic algebra. Linear extrapolation of the known  $\log K_N$  to  $(24!)^2$  (an estimated number of the “replicating creatures”) yields  $N = 256 = 2^{2^3}$  – a triple exponent(!). Both of these estimates may still support the “supra-wheel” idea in Figure 6(A), given their closeness to 240.

### **Combinatorial Coincidences**

Figure 6 (B) shows more possibilities.  $4! = 24$  could imply that each of 24 dimensions is a unique permutation of quaternions. Each permutation is a new sequence with 4 possible “stopovers” (e.g., 4 assignments of the real axis), thus yielding 96 “valid wheels”, which explains the number of material particles (below), and coincides with the numbers of faces and edges in a 24-cell.

Adding here the “trimmed” sequences (4 quatenionic + 3 spatial + 2 complex + 1 real) yields  $(1 + 2 + 3 + 4) \times 24 = 240$  – “all possible wheels”, coinciding with  $K_8$  and hopefully dimensions of the entire Universe.

$24! \sim 6 \times 10^{23} = N_A$  – Avogadro’s number, representing the number of molecules in a mole of substance, also approximate numbers of: protein molecules in a human body, cells in all humans cumulatively, moles of substance in an average planet, stars in a visible Universe. Thus, every star (as well as every molecule, cell, or mole) can be viewed as a unique combination of 24 opposites, hence 24 dimensions.

The number of “living creatures” (capable to replicate *via* mitosis) is  $\sim(24!)^2$ , whereas the number of all possible creatures is almost exactly  $(24!)^6$  (see below). For all of these reasons  $\Lambda_{24}$  associates with “Pure Love”, whereas  $N = 240$  – with Entire Universe.

These considerations are also supported by the  ${}^{240}C_{240}$  and  ${}^{240}C_{96}$  values – combinatorial distributions of 240 identical objects into 240 and 96 distinct bins, quite accurately explaining the size of the visible Universe and the number of particles in it (Figure 7).

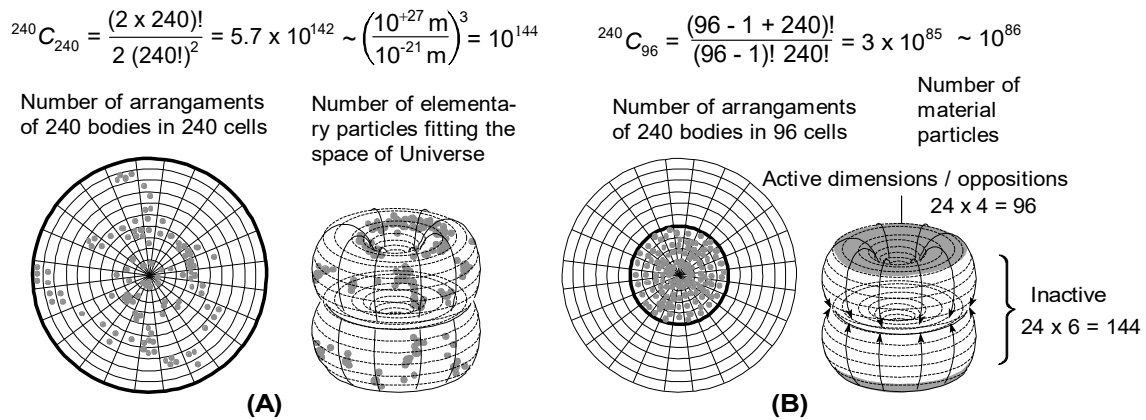

**Figure 7.** Distribution of 240 identical objects to 240 and 96 distinct cells

The first number ( ${}^{240}C_{240} = 5.681 \times 10^{142}$ ) is close to the number of elementary particles fitting the visible Universe (with diameters  $10^{-21}$  and  $10^{27}$  meters, respectively). This suggests that the entire Universe is filled with “aetheric” particles, each representing a unique combination of 240 “shallow oppositions”.  ${}^{240}C_{240}$  is unbelievably close to  $(24!)^6 = 5.705 \times 10^{142}$ , with log-error just 0.001%, suggesting that all particles constitute 6 layers of “collective consciousness” (recall, that  $24!$  is the approximate number of molecules, proteins, cells, moles, stars in various meaningful entities).

The second number ( ${}^{240}C_{96} = 3 \times 10^{85}$ ) is close to the number of material particles (fermions) in the Universe. It is obtained by arranging 240 objects into 96 distinct bins, representing unique quaternionic sequences (as explained above).

Thus 240 dimensions can also be viewed as both “energy bits” and “consciousness mechanisms”. If all bits come to “healthy” mechanisms ( $N = 4$ ), then we obtain a “real” particle with non-zero mass. But if at least one bit is wasted on a “sick” mechanism ( $N < 4$ ), then particle is “aetheric”, having no mass. It can “vibrate”, thus transferring the waves, but it cannot rotate, thus no mass.

### **How May it Work?**

It looks like non-commutativity is the simplest type of the “intellectual resistance”, overcoming which creates a mass. If you can imagine a continuous rotation of 4-D quaternions with sufficient speed, then (quite possibly!) you can create new mass.

The algebraic non-commutativity may also be the source of emotional non-indifference and conscience - the internal sense of right and wrong. So mass becomes inseparable from emotions and intellect! Above we saw that material particles activate only “healthy” mechanisms, thus offering predictability and confirming their



conscientiousness. Aetheric particles have no such feature, as they activate some “sick” mechanisms, like “trickery in lucid dreams”, and so they don’t have mass either.

The 3-level nesting scheme in Figure 6 (B) may indicate a 3-level psyche in healthy organisms:  $N = 4$  and 8 representing consciousness (normal and mitotic),  $N = 24$  and 240 – subconsciousness (Love and Creation),  $N = (24!)^1$  to  $(24!)^6$  – unconsciousness, reflecting all kinds of “collective consciousness”. The latter may have many smaller levels, due to various “smaller coincidences” (with log-errors  $< 0.13\%$ ):

$${}^{240}C_{240} \sim K_{240}^3 \sim (24!)^6 \sim K_{24}^{27} \sim K_8^{60} \sim 96^{72} \sim \dots \sim 4^{240}$$

(Note the “magic” repetition of numbers divisible by 2, 3, 4, 5. The multitude of such relations may indicate the complexity of networks that guide our thoughts and feelings. )

The multi-level nesting creates multiple possibilities for various “quasi-real” structures, that look “healthy” on the surface, but “sick” from inside. This poses the most serious threat to our health and morale, through presenting all Healthy Creatures as “inherently sinful beings that have to be controlled”. So we get to the world of “crooked mirrors” as in the novels of George Orwell.

(Consider for example the [Behavioral Sink](#) theory suggesting that all global problems arise from the plain “overcrowding” rather than disrupting deeper consciousness. So it calls for reduction of population rather than lifting intellect and restoring natural lifestyle(s). For achieving the Pure Intent ( $N = 4$ ) level, we have to activate two pairs of oppositions, but modern way of living makes it hardly possible.)

## **Conclusions and Suggestions**

The world is a much more elegant and magical place than we can presently imagine. Yet it is full of traps created by relativistic thinking and “quasi-real” constructs. We clearly need to propagate the ideas of dialectic thinking, panpsychism, and natural lifestyle.

## Literature

- Baez John (2013) Integral Octonions (Part 1)  
[https://golem.ph.utexas.edu/category/2013/07/integral\\_octonions\\_part\\_1.html](https://golem.ph.utexas.edu/category/2013/07/integral_octonions_part_1.html)
- Caballero, Jos´e Manuel Rodr´ıguez (2020) Brainstorming about the geometric structures in the Wolfram model of fundamental physics, Institute of Computer Science, University of Tartu, Tartu, Estonia. <https://arxiv.org/pdf/2006.01135.pdf>
- Capozziello, S.; Lattanzi, A. (2005) Chiral tetrahedrons as unitary quaternions: Molecules and particles under the same standard? Theoretical and Computational Developments. <https://doi.org/10.1002/qua.20613>
- Cohn, Henry; Kumar, Abhinav; Miller, Stephen D.; Radchenko, Danylo; and Viazovska, Maryna (2019), Universal optimality of the E8 and Leech lattices and interpolation formulas. <https://arxiv.org/pdf/1902.05438.pdf>
- Cole, Andrew (2017) How to Think a Figure; or, Hegel’s Circles, Representations (2017) 140 (1): 44–66. <https://doi.org/10.1525/rep.2017.140.1.44>
- Crowe, Michael. (1969). A History of Vector Analysis. American Journal of Physics. 37. 10.1119/1.1975883. <https://aapt.scitation.org/doi/10.1119/1.1975883>
- Furey C (2016) Standard model physics from an algebra?  
<https://arxiv.org/abs/1611.09182>
- Girard, P.R. (1984). "The quaternion group and modern physics". European Journal of Physics. 5 (1): 25–32. doi:10.1088/0143-0807/5/1/007.
- Girard, Patrick R. (1999). "Einstein's equations and Clifford algebra". Advances in Applied Clifford Algebras. 9 (2): 225–230. doi:10.1007/BF03042377. S2CID 122211720.

Linda Groff and Paul Smoker (1996), Spirituality, religion, culture, and peace: exploring the foundations for inner-outer peace in the twenty-first century, International Journal of Peace Studies, Vol. 1, No. 1, pp. 57-113

Lisi AG, Weatherall JO. A geometric theory of everything. Sci Am. 2010 Dec;303(6):54-61. doi: 10.1038/scientificamerican1210-54. PMID: 21141358.; <https://pubmed.ncbi.nlm.nih.gov/21141358/>

Makarieva, Anastassia; Gorshkov, Victor (2010-01-01). "[The Biotic Pump: Condensation, atmospheric dynamics and climate](#)". International Journal of Water. 5 (4): 365–385. CiteSeerX 10.1.1.459.6577. doi:10.1504/IJW.2010.038729

Petrauskas A. (2019) Atlas of Feelings available online: <http://laimeskeltas.lt/en/atlasas-v3?c=31>

Petrauskas A. (2021a) Plutchik Wheel and The Unity of Opposites, submitted to the Journal of Philosophy of Emotion: <http://laimeskeltas.lt/wp-content/uploads/2020/05/Plutchik-Wheel-and-Uniting-Opposites.pdf>

Petrauskas A. (2021b) Global Wisdom Network, <http://laimeskeltas.lt/universal-wisdom-network>

Tolman R. C., (1931) On the Problem of the Entropy of the Universe as a Whole, Phys. Rev. 37, 1639

Weinstein, Eric (2020). A Portal Special Presentation- Geometric Unity: A First Look. <https://youtu.be/Z7rd04KzLcg>